

HANDTORQUE™ MULTIPLIER WITH INTEGRAL TORQUE TRANSDUCER



PART NUMBERS COVERED BY THIS MANUAL

Model	Description
19108	Handtorque™ multiplier with integral torque transducer calibrated with TTT or similar Norbar display instrument. The calibration data is stored in the transducer.
19108.TRS	Handtorque™ multiplier with integral torque transducer calibrated as a system with a dedicated TRS-65 display.

SAFETY



Safety



Important: Do not operate the tool before reading these instructions. Failure to do so may result in personal injury or damage to the tool.

This tool is intended for use with threaded fasteners. Any other use is not recommended.

These tools require a reaction bar. See section on Torque Reaction.



There is a risk of crushing between the reaction bar and work piece.
Keep hands away from reaction bar.
Keep hands away from tool output.

INTRODUCTION

This operator's manual covers the setup and use of Norbar Handtorque™ multipliers with integral torque transducer. The multiplier retains all the features of the standard Norbar Handtorque™ including the anti wind-up ratchet safety device. In addition there is an integral torque transducer to ensure the applied torque can be measured (display instrument not included).

Parts Included

Part	Part Number
Cranked Reaction Bar	18494
Wrench	39635
Carry Case	26978
Operators Manual	34392

Accessories

Accessory	Options	Part Number
Drive Square	1" Drive Square (fixing screw)	18492 (25352.45)
Reaction Bars	Consult Norbar	Various
Display Instrument	TTT, TST, T-Box, Pro-Log, TTL-HE, TRS-65, etc.	Various
Transducer Lead	TTT, TST, T-Box, Pro-Log	60266.200
	TTL-HE	60245.200
	TRS-65	60292.200

NOTE: The Transducer Lead suffix after the part number indicates the length of the lead in cm, thus XXXXX.200 = 2 meters. If transducer leads are required of a non-standard length (to the nearest meter), the new suffix must be added to the part number when ordering.

Cleaning

Keep the tool in a clean condition to aid safety. Do not use abrasives or solvent based cleaners.

Disposal



This symbol on the product indicates that it must not be disposed of in the general waste. Please dispose of according to your local recycling laws and regulations.

Contact your distributor or see the Norbar web site (www.norbar.com) for further recycling information.

SPECIFICATIONS

Maximum Torque	2000 N·m (1450 lbf·ft)
Accuracy	+/- 1% of reading (400 – 2000 N·m).
Calibration units	N·m (as standard).
Calibration range	20% to 100% full scale.
Input Square	1/2"
Output Square	1"
Ratio	25:1
Dimensions	Height 240 mm Width 220 mm. Diameter 72 mm.
Weight	Multiplier 3.5 Kg. Reaction 0.7 Kg.

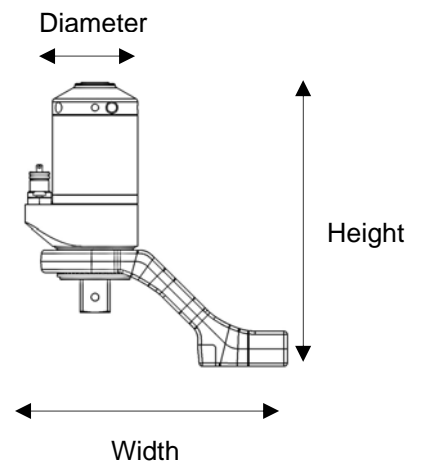

FIGURE 12 Dimensions



Important: The reported readings are only valid for the reaction path specified in the calibration method with the operator taking the input torque reaction. Any deviation from this path may invalidate the calibration.

NOTE: If the input torque is locked into the multiplier via the AWUR, the readings indicated by the display will increase by a factor of approximately 1.035.

Environment

Temperature Range:	0°C to +40°C. Storage -20°C to +60°C.
Altitude	Up to 2000m.
Maximum Operating Humidity:	Maximum relative humidity 80% for temperatures up to 31°C decreasing linearly to 50% relative humidity at 40°C.
IP code	IP 55

Due to continuous improvement all specifications are subject to change without prior notice.

TRS-65



PART NUMBERS COVERED BY THIS MANUAL

Part Number	Description
43257	TRS-65

SAFETY



IMPORTANT: DO NOT OPERATE THE PRODUCT BEFORE READING THESE INSTRUCTIONS. FAILURE TO DO SO MAY RESULT IN PERSONAL INJURY OR DAMAGE TO THE PRODUCT.

This product is intended for measuring torque from compatible transducers. Any other use is not recommended.

Keep this manual available for whenever necessary.

INTRODUCTION

This operator's manual covers the setup and use of the Norbar TRS-65 display. The TRS-65 is a portable torque measuring display intended for slow applications of torque, such as from the output of a torque multiplier. For most applications the TRS-65 display is calibrated with a transducer to form a dedicated system; in these cases the transducer can be given a part number with a ".TRS" suffix (e.g. 19108.TRS).



WARNING: THE PEAK / TROUGH MODES ARE ONLY FOR MEASURING 'SLOW' APPLICATIONS OF TORQUE (E.G. TORQUE MULTIPLIER & DIAL TORQUE WRENCH).

THE TRS-65 IS NOT INTENDED TO MEASURE 'FAST' APPLICATIONS OF TORQUE (E.G. CLICK TORQUE WRENCHES, TORQUE SCREWDRIVERS, PULSE TOOLS, CLUTCH TOOLS, ETC)

Parts Included

Description	Quantity	Part Number
TRS-65	1	43257
Battery 1.5V AA	2	39633
Operator's Manual	1	34391

Accessories

Accessory	Option	Part Number
Transducer Lead	TRS-65 to HE Transducer	60292.200
	TRS-65 to 6 Way Transducer for use with Norbar Static & Annular Transducers	60293.200
	TRS-65 to 10 Way Transducer for use with Norbar Rotary Transducers	60294.200

NOTE:- The suffix after the part number indicates the length of the lead in cm, thus XXXXX.200 = 2 meters. If Transducer leads are required of a non-standard length (to the nearest meter), the new suffix must be added to the part number when ordering.

FEATURES AND FUNCTIONS

- Handheld and lightweight.
- Powered by 2 AA internal battery.
- Ranges of N·m & lbf·ft (as standard).
- Separate maximum torque for clockwise (Peak) & counter-clockwise (Trough).
- Display setting(s) shown on 8 annunciators at the bottom of the display.
- Environmentally sealed to IP65 rating (with transducer lead connected).
- When used in conjunction with a Norbar transducer to form a torque measuring system; a UKAS accredited calibration certificate can be issued for the system calibration.

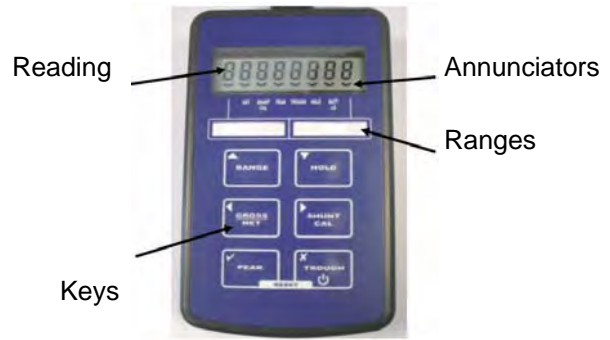

The 6 front panel keys are:

Key	Function	Action
	Change range (units) between N·m & lbf·ft.	Press to change. Annunciator on N·m or lbf·ft
	Hold (freeze) the display. Will not work in PEAK or TROUGH mode.	Press to hold. Annunciator on HOLD. Reading will flash. Press again to remove hold.
	Change between GROSS & NET. Use only in GROSS mode.	Keep in GROSS mode. Annunciator is OFF.
	Shows a display check value, see MAINTENANCE section for details.	Press and hold to display value Annunciator on SHUNT CAL. Reading will flash.
	Displays positive peak (highest clockwise) reading. Ensure peak is reset (press PEAK & TROUGH together) before using.	Press for PEAK mode. Annunciator on PEAK. Reading will flash.
	Displays negative trough (highest counter-clockwise) reading. Ensure trough is reset (press PEAK & TROUGH together) before using. Hold key to turn TRS-65 ON / OFF.	Press for TROUGH mode. Annunciator on TROUGH. Reading will flash. Hold 3 seconds for ON / OFF.

Annunciator	Options	Action
RANGE	N·m or lbf·ft	Press RANGE to select.
NET	OFF (NET) or ON (GROSS)	Use only in GROSS mode. Ensure annunciator is OFF.
SHUNT CAL	Press to view.	See MAINTENANCE section for details.
PEAK	OFF (track) or ON (clockwise reading)	Measuring maximum clockwise torque.
TROUGH	OFF (track) or ON (counter-clockwise reading)	Measuring maximum counter-clockwise torque.
HOLD	OFF (live) or ON (hold)	If ON hold display reading.
BATT LOW	OFF (battery OK) or ON (battery low)	If ON change battery, see MAINTENANCE section.

SET-UP INSTRUCTIONS

NOTE: If the equipment is used in a manner not specified by the manufacturer, the protection provided by the equipment may be impaired.

Connect transducer. The TRS-65 has been calibrated as a system with one transducer; see Certificate of Calibration for details. Only use the TRS-65 display with the correct transducer & transducer lead.

TRS-65 Set Up

The TRS-65 has been factory set-up. If during use the zero needs adjusting or the auto power off changing use the following procedure to change:

Step	Item
1	To turn on press  for 3 seconds
2	Select N·m or lbf·ft.
3	Note the zero value.
4	Press RANGE & GROSS/NET buttons <u>together</u> for 3 seconds.
5	Set Zero (Display shows “SEt 2Er0”). This allows a zero offset to be typed in. <u>Press X to skip:</u> or <u>Press tick to change:</u> Use ◀▼▶▲ keys to enter a value to subtract from the current display zero. <u>Press tick.</u> Note: To change the sign (-) press ▲ on left hand digit.
6	Set display rate (Display shows “SEt rAtE”). The display rate is factory set to the maximum of 25. <u>Press X to skip.</u>
7	Set over (Display shows “Set 0UEr”). This sets an overload value; not used. <u>Press X to skip.</u>
8	Set power saving mode (Display shows “Set 0PEr”). Not used as affects accuracy. <u>Press X to skip.</u>
9	Auto power off time (Display shows “AUt0 OFF”). Factory set to 10 minutes. <u>Press X to skip:</u> or <u>Press tick to change:</u> Use ◀▼▶▲ keys to enter value in minutes. Enter 0 for off. <u>Press tick.</u>
10	RS232 output (Display shows “rS232”). Not enabled. <u>Press X to skip.</u>
11	TRS-65 returns to normal display.

NOTE: The above settings are for either the N·m range or the lbf·ft range.
Repeat procedure if both ranges are used.

TIP: To assist in the “Set zero” feature, the process can be repeated twice.
The first time the “Set Zero” value is set to “00000.0”, then exit the setup. Note the zero.
The second time the “Set Zero” value is set to the zero value just noted.

OPERATING INSTRUCTIONS

Turn On

Press  for 3 seconds.

Ensure all annunciators (except N·m or lbf·ft) are OFF:

Annunciators							
V							
N·m	NET	SHUNT CAL	PEAK	TROUGH	HOLD	BATT LOW	lbf·ft

Leave to warm up for 5 minutes.

Ensure transducer had no torque. If the display shows a value, note this zero value and enter it in the Set Zero “**SEt 2Er0**” feature in the SET UP INSTRUCTIONS.

The TRS-65 is ready to use, it will measure the ‘live’ torque applied by the transducer.

To hold the reading press  Reading will flash to show display is held.

Measure Maximum Torque

Most torque applications require the maximum torque to be displayed.

For clockwise maximum torque press  PEAK annunciator is on:

Annunciators							
V			V				
N·m	NET	SHUNT CAL	PEAK	TROUGH	HOLD	BATT LOW	lbf·ft

For counter-clockwise maximum torque press  . TROUGH annunciator is on:

Annunciators							
V				V			
N·m	NET	SHUNT CAL	PEAK	TROUGH	HOLD	BATT LOW	lbf·ft

When the transducer is loaded the TRS-65 will show the peak torque in that direction.

When measuring the maximum torque the reading will flash.

The display will show the maximum value since last reset, even if the TRS-65 has been turned off.

The PEAK and TROUGH maximum values get constantly updated whilst in any mode.

Press PEAK & TROUGH together to reset the maximum values.

Turn Off

Press  for 3 seconds.

MAINTENANCE

Battery Replacement

1. Ensure TRS-65 is clean & dry.
2. Remove 2 rear screws at bottom of case.
3. Replace batteries.
4. Replace battery cover.



Batteries contain substances that can have a negative effect on the environment and human health so must NOT be disposed of in the general waste. All batteries must be disposed of at a local waste battery collection point.

'Shunt Cal' Display Check

The TRS-65 has a display check feature to give an indication it is still operating correctly; this feature does not take the place of a calibration. To check the display:

1. Ensure peak is OFF.
2. Ensure torque is zero.
3. Press  and note reading. Use in future to ensure display is giving consistent result

Calibration

The TRS-65 is only calibrated with a dedicated transducer.

To maintain the specified accuracy it is recommended that the TRS-65 & transducer are re-calibrated at least once per year. Re-calibration should be carried out at Norbar or by a Norbar approved agent, where all the facilities to ensure the instrument is functioning at maximum accuracy are available.

Do not remove the case; there are no calibration settings inside.

Repair

Repair should be carried out at Norbar or by a Norbar approved agent, where all the facilities to ensure the instrument is functioning at maximum accuracy are available.

Do not remove the case; there are no parts for operator repair inside.

Cleaning

Keep the TRS-65 in a clean condition to aid safety. Do not use abrasives or solvent based cleaners.

Disposal



This symbol on the product indicates that it must not be disposed of in the general waste. Please dispose of according to your local recycling laws and regulations.

Contact your distributor or see the Norbar web site (www.norbar.com) for further recycling information.

SPECIFICATIONS

Accuracy	See calibration certificate supplied with transducer.
Ranges (Units)	N·m & lbf·ft (as standard).
Non linearity	+/-0.005% full scale deflection.
Thermal drift	<25ppm/ °C.
Offset stability	0.002 typical (0.008 maximum) +/-% full scale from original offset.
Gain stability	0.003 typical (0.01 maximum) % per annum.
Battery	2 x AA alkaline, access via sealed rear compartment.
Battery life	45 hours with 350Ω sensor.
Auto Off	10 minutes (user settable).
Display	7 digit LCD 8.8mm high.
Display update rate	0.3Hz.
Sample rate	25Hz (PEAK & TROUGH mode).
Display resolution	5 digits.
Weight	265 g.
Dimensions:	

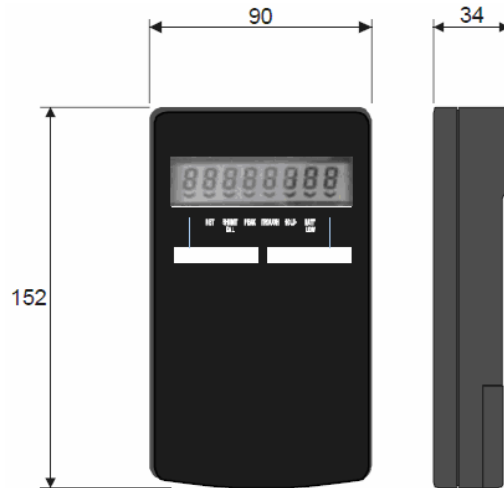

Environmental

Location	Indoor use.
Temperature Range:	Storage -40°C to +65°C. Operating -10°C to +50°C.
Altitude	Up to 2000m.
Maximum Operating Humidity:	95% maximum non-condensing.
Enclosure type	ABS.
Ingress Protection code	IP 65 (with transducer lead connected).

Conformity

Electromagnetic Compatibility (EMC) Directive	In conformance with EN 61326:2006.
---	------------------------------------

INTERFACING WITH NON NORBAR TRANSDUCERS

Required transducer type	Full strain gauge bridge.
Excitation voltage	5 Volts D.C. (+/-4%) 59mA maximum current
Strain gauge impedance	85 ohm to 5000 ohm
Sensitivity	+/- 5mV/V
Transducer connector	PIN 1 +ve Excitation PIN 2 -ve Excitation PIN 3 +ve Signal PIN 4 -ve Signal PIN 5 DO NOT USE
Transducer connector type	Binder 723 series 5 pin.

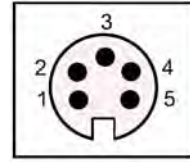

Electromagnetic compatibility is the responsibility of the system designer. To help in this task Norbar recommend the following:

- (i) Use good quality screened transducer cable.
- (ii) Keep transducer cable length to a minimum.
- (iii) Keep transducer cable away from high voltage cables.

Due to continuous improvement all specifications are subject to change without prior notice.

TROUBLESHOOTING

Common problems are listed below, for more complex faults please contact your local Norbar distributor or Norbar directly.

Problem	Likely Solutions
No Display	In Auto-Off mode, can be changed in set-up instructions. Batteries low, see Maintenance section to change batteries.
Batt Low annunciator on	See Maintenance section to change batteries.
Reading does not increase	In wrong maximum mode. Ensure PEAK for clockwise & TROUGH for counter-clockwise.